



**BARDIC**

by Honeywell

# Central Battery Systems

**System Design Notes**

**AC Battery Systems**

**DC Battery Systems**

**Wattage Rating**

**Sub-circuit Monitoring**

**Switch Tripping Systems**

# System Design Notes

## SELECTING A CENTRAL SYSTEM BATTERY

The main points to consider when selecting a battery type are the required life of the installation and the pattern of investment required i.e. is a lower initial cost more important than the total cost over the life of the system, inclusive of maintenance. These considerations determine which battery may be most suitable. Example shown below:

BATTERY	INITIAL COST	DESIGN LIFE	MAINTENANCE
Sealed Recombination Lead Acid	••	••	••
Lead Acid Planté	••••	••••	••••
Vented Nickel Cadmium	•••••	•••••	•••••
• = Scale of Cost			

## BATTERY TYPES

### Gas Recombination Lead Acid

Maintenance limited to periodic voltage checks. No special battery room needed.

**Compact design** – Takes up less space than other battery types.

**Up to 10 year design life at 20°C**

**Low initial cost**

**Disadvantages** – Low voltage cut-off required, cannot be left discharged.

### Vented Lead Acid Planté

**Complies with BS 6290 Part 1 and 2** – Designed for 25 years life.

**Pure lead positive plate** – Provide full capacity throughout life.

**Clear containers** – For visual inspection of electrolyte and plates.

**Disadvantages** – Relatively high cost – bulky and heavy, cannot be left discharged for prolonged periods, needs regular maintenance, ventilated battery room required.

### Vented Nickel Cadmium Alkaline

**Advantages** – Long design life – 25 years.

**Resistance to abuse and temperature variations**

**Disadvantages** – Highest initial cost of the three battery types, ventilated battery room needed. High maintenance costs. Requires to be topped up.

## WIRING, MAINTENANCE AND TESTING CONSIDERATIONS

### Cable sizing and voltage drop for centrally supplied systems

As slave luminaires can be positioned a substantial distance from their power source (the central system) and since they must be wired in suitably protected cable, sizing must be carefully considered.

### Fire protection of cables systems (BS 5266 Part 1, Clause 9.2.2)

The following cables or cble systems should be used:

- 1 Cables with an inherently high risk to attack by fire should have a duration of survival of 60 minutes when tested in accordance with BS EN 50200: 2000. Cables to conform to BS EN 60702-1, BS 7629 or to BS 7846.
- 2 Cables systems requiring additional fire protection
  - a Cable conforming to BS 6004 or BS 7211 must be in conduit conforming to BS EN 50086
  - b Steel wire armoured cables conforming to BS 5467 or BS 6724

Bardic central battery systems are rated to ensure that at the end of the discharge the battery voltage is not less than 90% of nominal voltage, as required by BS EN 50171. But, in order to maintain the light output expected of slave luminaires, it is essential to limit cable voltage drop. BS 5266-1: 2005 limits cable voltage drop to 4% of nominal voltage so that lighting schemes can be designed with confidence using published spacing tables. The following table is provided as a guide to current rating and volt drop per metre length for typical mineral insulated cable, which is the most commonly used cable for emergency lighting installations.

NORMAL CROSS SECTIONAL AREA (mm <sup>2</sup> )	CURRENT RATING (AMPS)	VOLT DROP PER AMP PER METRE (mV)
1.0	14	42
1.5	16	28
2.5	23	17
4.0	31	10
6.0	40	6.9
10.0	57	4.2
16.0	80	2.6
25.0	109	1.7
35.0	138	1.2

This table is based on two single core mineral insulated cables with copper connection to BS 6207 Part 1 and is intended as a guide only. Cables of less than 1.00mm<sup>2</sup> should not be used. By applying the values for a particular system the correct cable size can be chosen:

$$MV = \frac{\text{Volt drop} \times 1000}{I \times L}$$

Where volt drop = 1V, 2V, 4.5V, for 24V, 50V for 110V systems.

I = load current in amps, L = cable length in metres.

Select a cable from the above table such that the mV value is equal to or less than the calculated value and the selected cable's current rating exceeds the load current. If a suitable cable size is not identified, alternative ways of overcoming excessive voltage drop should be considered:

- i Increase the system voltage to 50V or 110V. If 110V DC system is impractical, a 240V AC sinewave inverter system may be considered.
- ii Increase the number of distribution circuits.
- iii Reduce cable runs, e.g. consider separate central systems to cover different parts of a building.
- iv Use cable grading from the central system to luminaires.
- v Use 'ring' type wiring circuits.

### Maintenance and testing

The tasks of regular maintenance and testing are vital to make sure that a systems integrity and capacity to fulfil its task are maintained at all times.

BS 5266 Part 8: 2004 Clause 7 details Servicing and Testing.

Honeywell Service can offer a comprehensive range of testing and maintenance solutions.

# AC Battery Systems Features

- High efficiency and reliability
- Low operating cost
- Wide range of standard ratings available, with batteries to suit all applications
- For use with a wide range of normal mains voltage fittings
- High light levels achievable

ACE AC Emergency Lighting Systems are designed to provide up to 3hrs of reliable, continuous power to selected luminaires, exit signage and other life safety devices in the event of a power failure. ACE products are available from 600VA to 100kVA.

ACE AC Emergency Lighting Systems will effectively supply emergency power to all electronic fluorescent ballasted luminaires, as well as any combination of HID, compact fluorescent, LED exit signage, building management systems, or other critical life safety loads.

All ACE products are CE marked and utilise the latest technology to enhance the reliability of all critical system functions.

## System Operation

During mains healthy conditions the maintained load is supplied via a bypass circuit within the inverter systems from normal mains. When the mains fails the DC voltage from the standby battery is converted to AC by the inverter and a good quality sine wave at 230 volt AC is supplied to the load. The static inverters are supplied in the passive standby mode of operation; this means that the inverter only operates when the mains supply fails.

The principle advantages of the AC systems is that the wide range of light fittings available for use with normal mains can be used with the inverter. This results in higher light levels being achieved when using AC systems than achieved using the traditional low voltage emergency luminaires.

When sizing an inverter it is essential that one ensure that the running wattages of the light fittings are taken into account.

When sizing a sine wave emergency lighting inverter the following should be considered:

- 1 The fittings circuit wattage should be used when calculating the inverter rating. Not the lamp wattage, they can be substantially different.
- 2 HF fitting will normally have a lower circuit wattage than its equivalent switch start fitting. If HF fittings are used it will result in a much smaller inverter.
- 3 Low power factor fittings have a much higher VA than fittings with a high power factor. If high power factor fittings are used a smaller inverter will be required.
- 4 Note standard glow starters or lamps with built in starters must be not be used. Use electronic starters.
- 5 Both the total VA and total wattage must be calculated.
- 6 When the total load is calculated a spare capacity should be added on for future expansion.



# Sine Wave Inverter

## Technical Specification



by Honeywell

The Bardic ACE range of Sine Wave Inverters comply with the requirements of BS EN 50171: 2001 – the standard for the design and construction for central power supply systems.

They are designed to operate in a passive standby mode which means they are able to provide full power to the emergency lighting load from cold (previously un-powered load) within the time limits of EN 1838.

SINE WAVE INVERTER TECHNICAL SPECIFICATION	
Rating	600VA to 22KVA Single Phase in / Single Phase Out 10KVA to 100KVA Three Phase in / Three Phase Out
Supply Input	230V +/-10% 50Hz Single Phase 400V +/-10% 50Hz Three Phase
Output Voltage	230V +/-10% 50Hz Single Phase 400V +/-10% 50Hz Three Phase Output configured for maintained output as standard, non-maintained output also available. Control Link 1 allows the inverter to go into emergency mode when open. Can be used for sub-circuit monitoring. Control Link 2 allows the system to operate in the non-maintained mode or allows switching of maintained lights (MCR).
Output Frequency	50Hz +/-1%
Harmonic Distortion	Less than 5%
Mode of Operation	Under normal operation the load is fed via a bypass circuit, the inverter is off. Battery is on charge. When the mains fails the changeover contactor operates, the inverter starts and the load is supplied with AC power derived from its batteries. This transfer is within limits set within EN 1838. When the mains supply returns to normal the system returns to normal operating mode supplying the load with AC power from the input mains supply. At the same time the charger is energised and recharges the battery. (This occurs even if deep protection device has operated.) The Battery feeds into the system through a magnetically latched contactor. If the system is in the emergency mode for an extended period that is longer than the rated discharge the control circuits sense that the batteries are discharged and drives the battery contactor open. This will shut down the system with no drain on the batteries protecting them from deep discharge, The operation of the deep discharge protection is indicated on the front panel of the system.
Battery	All types available
Charger	Solid state constant voltage, capable of recharging the battery within 12 hours to enable the system to operate for at least 80% of its rated autonomy at its rated load following full discharge.
Changeover Devices	Change over contactor comply with EN 60947-4-1 and for emergency lighting loads the switching thresholds conform to EN 60598-2-22. The inverter is not energised until the contacts are closed and is not shut down before changing back to the normal supply.
Indicators	System OK – green LED Float – green LED Mains fail – red LED High volts – red LED Low volts – red LED Charging – amber LED Charger fail – red fail LED Low battery – red LED Battery discharged – red LED Summary remote terminals – a set of volt free alarm changeover contacts that allows for an interface to either a remote common alarm unit or the building control circuits or both. If any of the systems alarms are triggered the contacts will give an alarm.
Switches	Charger input MCB Output MCB Inverter test push button
Meter	Digital meter – indicates battery voltage and charge / discharge.
Terminations	AC input and output, with access via full width un-drilled gland plate in top back of cubicle.
Acoustic Noise	Less than 55dBA at 3 metres on standby Less than 70dBA at 3 metres when active
Cubicle Construction	Welded sheet steel construction, generally of 1.4mm thick mild steel. Thermosetting polyester epoxy power coated to RAL 7035. Protection is provided to IP21 of BS 5420. The doors are locked using a key that is provided with the system. Forced cooling by fans, which only operate during emergency operation. During normal operation natural convection provides sufficient cooling.
Ambient Temperature	Performance figures measured at 20°C Operating temperature: 0°C to +40°C Storage temperature: -20°C to +70°C

# AC Battery Systems

## Technical Specification

### Single Phase In / Single Phase Out

Inverter range which requires a 230 volt +10% to 15% 50/60 Hz single phase input. Output 230volt +/- 5% 50/60Hz +/- 0.1%. 1 hour, 2 hour and 3 hour options available. Can be supplied with all battery types.

A very flexible range of inverters from 500VA to 22KVA. Single phase input with single phase outputs as standard. A full range of battery system control and monitoring is available. This includes phase failure monitors, sub-circuit monitors, fire alarm monitors, output distribution, nightwatchman switching and earth fault alarms.

SINGLE PHASE IN / SINGLE PHASE OUT		1 HOUR		3 HOUR	
Unit kVA	Unit kW	Unit cabs HxWxD	Battery cabs HxWxD*	Unit cabs HxWxD	Battery cabs HxWxD*
0.6	0.5	1 x 1425x600x400	NR	1 x 1425x600x400	NR
1	0.9	1 x 1425x600x400	NR	1 x 1425x600x400	NR
1.5	1.3	1 x 1425x600x400	NR	1 x 1425x600x400	NR
2	1.7	1 x 1625x600x400	NR	1 x 800x600x400	1 x 1350x600x400
2.5	2.1	1 x 1625x600x400	NR	1 x 800x600x400	1 x 1550x600x400
3	2.6	1 x 1350x600x400	1 x 1350x600x400	1 x 1350x600x400	1 x 1750x700x700
4	3.4	1 x 1350x600x400	1 x 1350x600x400	1 x 1350x600x400	1 x 1750x700x700
5	4.3	1 x 1350x600x400	1 x 1350x600x400	1 x 1350x600x400	1 x 1750x700x700
6	5.1	1 x 1350x800x400	1 x 1350x600x400	1 x 1350x800x400	1 x 1750x700x700
7	6.0	1 x 1350x800x400	1 x 1750x700x700	1 x 1350x800x400	1 x 1750x700x700
8	6.8	1 x 1350x800x400	1 x 1750x700x700	1 x 1350x800x400	1 x 1750x700x700
10	8.5	1 x 1550x800x500	1 x 1750x700x700	1 x 1550x800x500	2 x 1750x700x700
12	10.2	1 x 1750x800x500	1 x 1750x700x700	1 x 1750x800x500	2 x 1750x700x700
15	12.8	1 x 1750x800x500	1 x 1750x700x700	1 x 1750x800x500	3 x 1750x700x700
20	17.0	1 x 1950x800x500	2 x 1750x700x700	1 x 1950x800x500	3 x 1750x700x700
22	18.7	1 x 1950x800x500	2 x 1750x700x700	1 x 1950x800x500	4 x 1750x700x700

### Three Phase In / Three Phase Out

A very flexible range of inverters from 10KVA to 100KVA are available as standard. Supplied as standard with Sealed Lead Acid batteries, a wide range of battery choice are available. Please consult are technical sales office for further details.

THREE PHASE IN / THREE PHASE OUT		1 HOUR		3 HOUR	
Unit kVA	Unit kW	Unit cabs HxWxD	Battery cabs HxWxD*	Unit cabs HxWxD	Battery cabs HxWxD*
10	8.5	1 x 1750x800x500	1 x 1750x700x700	1 x 1750x800x500	2 x 1750x700x700
15	12.8	1 x 1750x800x500	1 x 1750x700x700	1 x 1750x800x500	3 x 1750x700x700
20	17.0	2 x 1550x800x500	1 x 1750x700x700	2 x 1550x800x500	3 x 1750x700x700
25	21.3	2 x 1750x800x500	2 x 1750x700x700	2 x 1750x800x500	4 x 1750x700x700
30	25.5	2 x 1750x800x500	2 x 1750x700x700	2 x 1750x800x500	5 x 1750x700x700
35	29.8	2 x 1750x800x500	3 x 1750x700x700	2 x 1750x800x500	6 x 1750x700x700
40	34.0	2 x 1950x800x500	3 x 1750x700x700	2 x 1950x800x500	6 x 1750x700x700
45	38.3	2 x 1950x800x500	3 x 1750x700x700	2 x 1950x800x500	7 x 1750x700x700
50	42.5	3 x 1750x800x500	3 x 1750x700x700	3 x 1750x800x500	8 x 1750x700x700
60	51.0	3 x 1750x800x500	5 x 1750x700x700	3 x 1750x800x500	10 x 1750x700x700
70	59.5	3 x 1750x800x500	5 x 1750x700x700	3 x 1750x800x500	Battery stand
80	68.0	3 x 1950x800x500	6 x 1750x700x700	3 x 1950x800x500	Battery stand
90	76.5	3 x 1950x800x500	6 x 1750x700x700	3 x 1950x800x500	Battery stand
100	85.0	3 x 1950x800x500	7 x 1750x700x700	3 x 1950x800x500	Battery stand

\* Battery Cabinets can be replaced with Battery Stands, please consult Technical Sales for dimensions.

# DC Battery Systems Features and Operation Modes

- Wide range of standard ratings
- Extensive choice of battery types
- Comprehensive instrumentation and monitoring
- Bardic DC central emergency power systems automatically provide an alternative lighting supply in the event of AC supply failure
- Long battery design life of between 5 and 25 years depending upon the type chosen
- Comprehensive ranges of options are available to customise equipment to each individual application

Bardic DC central emergency power systems are designed to comply with BS EN 50171: 2001.

The quality system operated within our production facility is designed to meet the requirements of ISO 9002.

Honeywell Services offer a full commissioning, maintenance and break-down package, covering all the DC range of products. Please contact Honeywell Services for more information.



## Q Circuit

This is a system that is used in applications where remote hold-off or changeover devices will be used. Common applications include hospital theatre lighting and fire alarm power units.

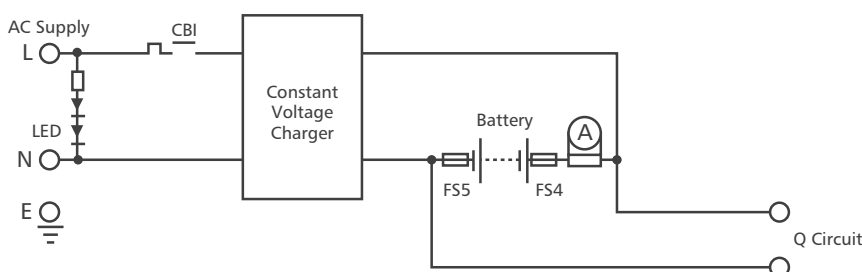

## Non-Maintained

A non-maintained central emergency power system will supply a DC source to the luminaires only in the event of an AC supply failure. Factory-fitted or remotely-mounted sub-circuit fire alarm or phase monitoring relays can also achieve control of the emergency lighting.

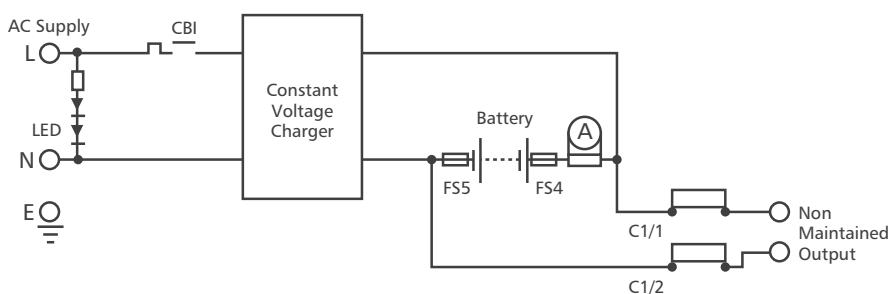

# DC Battery Systems

## Operation Modes

### Maintained

In maintained systems a supply is provided at the output at all times. The output is AC via an isolating transformer whilst the mains input AC supply is present, and automatically changes over to DC during mains input AC supply failure.

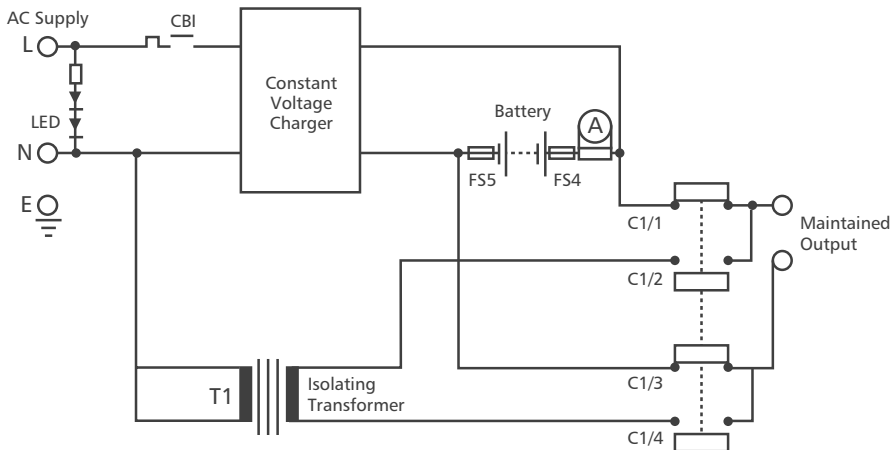

### Dual Output, Maintained and Non-Maintained

According to the requirements of BS EN 50171, all central emergency power system outputs must have both poles switched. Therefore where dual maintained and non-maintained outputs are required, two separate outputs are required. Both the maintained transformer and the non-maintained contactor can be sized to give the optimum rating for a given application.

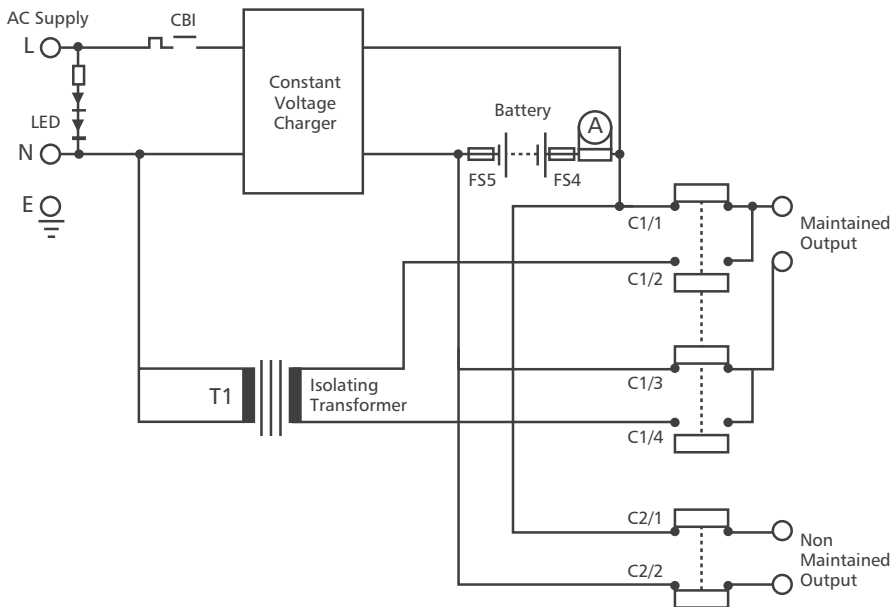

### Cubicles

The cubicles are fabricated from 1.6mm minimum folded sheet steel to provide a degree of protection of IP22 classification and are finished in acid and alkaline resistant light grey powder coating to BS 381C shade 631. A gland plate is provided for top cable entry for floor-maintained units, and bottom cable entry for wall-mounted units.

Ventilation is provided by louvres. A removable cover gives access to the control equipment. Instruments, indicators and controls are mounted on a fascia panel. The S2 cubicle is designed for wall mounting.

CUBICLE DIMENSIONS				
List number	Height (mm)	Width (mm)	Depth (mm)	Mounting
S2	610	750	400	(Wall Mounted)
S4	1330	750	560	(Floor Mounted)
S5	1730	750	560	(Floor Mounted)
S6	1730	1050	560	(Floor Mounted)

### Monitors

The control panel shall include battery voltmeter and charge/discharge ammeter to BS 89, lockable mains MCB, float/boost panel mounted keyswitch and LED indicators to show float charge (green), boost charge (amber) and mains present (red), mains fail (amber), charge fail (amber), high volts (amber), low volts (amber).

### Charger

The charger is a constant voltage type with self protecting current limit to provide protection against low battery volts, reversed battery connection and short circuit conditions. The output voltage is controlled to within +/- 1% irrespective of input supply variations of +/- 6% and output current variation from 0 to 100% of rated value. Ripple voltage will not exceed 2% RMS of DC nominal voltage. The charger is capable of recharging the battery in accordance to EN BS 50171.

### Change-Over Contactor

The contactor is constructed to EN 60947-4-1 and EN 50272-2 as standard, but a contactor meeting the requirements of BS 764 is also available.

### Maintained Transformer

The transformer is designed and constructed to BS 171 and the output is regulated to ensure a voltage variation of not more than 5% from zero to full load current. It is provided with primary tapplings of 10-0-220-240V and secondary output of 22-24-26-28 for 24 volt systems.

# DC Battery Systems

## Operational Features

To further tailor a central emergency power system for a specific application, the following optional features can be included.

### **Remote Alarm Relays (RAR)**

Individual relays connected to any or all of the alarm functions of the central emergency power system. They are used to give remote indication of a specific alarm condition or for connection into a building management system (BMS).

### **Remote Alarm Unit (RAU)**

Operating from the system battery and connected into the standard summary remote alarm contacts, this unit provides both audible and visual indication of a fault arising with the central emergency power system. The audible signal can be muted by the push button provided, but the visual signal will continue until the fault has been cleared. This unit is intended for use in continuously occupied areas such as a reception or a caretaker's office.

### **Rapid recharge**

All Bardic DC central emergency power systems have chargers sized to be capable of automatically charging the discharged battery so that they can perform at least 80% of their specified duration within 12 hours of commencement of charge.

### **Output distribution**

Distribution fuses or MCBs are mounted in a separate compartment behind a removable cover and are accessible from the front of the cubicle. Double Pole HRC shrouded fuses or DP MCBs are used for distribution. Each should be sized to protect the given lighting sub-circuit. Where MCBs are used they can be supplied with locking slides to provide a lockable output facility.

### **Automatic boost**

A solid state timer automatically selects the boost mode for a specific period during the recharge cycle. This ensures full battery capacity is returned without any manual intervention, within the specified time. Manual override is possible by use of the panel-mounted keyswitch provided with this option. This option is not available for Sealed Lead Acid Battery.

### **Phase Failure Monitor (PFM)**

A factory-fitted pair of relays is used to ensure a system monitors all three phases of an incoming supply. Failure of any phases activates the emergency lighting system.

### **Sub-Circuit Monitor (SCM)**

Either factory-fitted or remotely-mounted, these relays monitor local lighting sub-circuits or remote phases. Failure of any phase or sub-circuit activates the emergency lights. Three of these relays can be interconnected to provide 3-phase monitoring.

### **Fire Alarm Monitoring (FAM)**

Either factory-fitted or remotely-mounted relays are used in conjunction with a fire alarm system, operating from a 24V DC supply. An alarm condition on the fire alarm panel will activate the emergency lights. Any number of the above monitor relays may be connected together with their normally closed contacts wired into the appropriate control link.

### **Nightwatchman switching**

For loads less than 2KW, a remote nightwatchman switch may be connected directly into the link, controlling the primary side of the maintained transformer, enabling switching of the maintained lighting from a remote location. As direct switching is not failsafe in operation, armoured or mineral insulated cable would be required. This switching facility does not effect the 'Emergency' operation.

# DC Battery Systems

## Operational Features



### Maintained Control Relay (MCR)

By including an additional relay to control the primary circuit, it is possible to provide a system with a failsafe method of nightwatchman switching and local monitoring. The switch, plus any normally closed monitor contacts (such as phase failure, subcircuit or remote fire alarm monitors), are wired in series and connected to the maintained control relay. Any contact opening will illuminate the maintained lighting. As this circuit is both failsafe and low current, 1.0mm PVC cable is sufficient for wiring a remote switch. This switching facility does not effect the 'Emergency' operation.

### Timer control

Connected into the control circuitry, a solar dial or 24 hour timers can be used to switch the maintained lights. These timers are used to ensure the maintained lighting is illuminated only during hours of occupation. The solar dial timer also allows for seasonal variations. The 3 position keyswitch provided with this option can be either panel-mounted or remote and provides the choice of maintained, non-maintained or timer-controlled operation.

### Optional monitors

In addition to those monitors supplied as standard, the following monitors may be included to further enhance the complete system.

### Earth Fault Alarm (EFA)

Used to detect and give visual indication of leakage current to earth from either pole of the battery. Sensitivity 6mA.

### Model designations

- 1 Battery Type
  - V** Sealed Lead Acid
  - P** Lead Acid
  - A** Nickel Cadmium Vented
- 2 Mode of Operation
  - M** Maintained
  - NM** Non-Maintained
  - Q** Q Circuit
- 3 Voltage 24 Volts, 50 Volts, 110 Volts
- 4 Duration 1 hour, 2 hour, 3 hour
- 5 Battery Capacity
- 6 When options are required, options should be identified separately

### For Example

#### **V/NM/110/3/120**

This designates a system to provide a non-maintained output, 3 hour duration at 110 volts, with a battery capacity of 120 AH, using sealed lead acid batteries.

# Battery Systems Wattage Ratings

## High Performance Planté Cells

High Performance Lead Acid Planté cells are designed for 25 years life. They comply with BS 6290 (Parts 1 and 2) and EN 60896-1 and are engineered to provide full rated capacity during life with clear containers showing condition of the plates and the electrolyte level.

24 VOLT				
CELL MODEL	1 HOUR	2 HOUR	3 HOUR	CUBICLE
15	215	130	95	S4
30	430	260	190	S4
45	650	390	290	S5
60	860	520	385	S5
75	1080	650	480	S5
100	1440	867	640	S6
125	1800	1084	795	S6
150	2160	1301	954	S6
200	2400	1726	1272	S6
250	-	2168	1590	S6
300	-	2400	1908	S4 + Rack

50 VOLT				
CELL MODEL	1 HOUR	2 HOUR	3 HOUR	CUBICLE
15	450	271	200	S5
30	900	542	400	S5
45	1350	813	600	S6
60	1800	1084	800	S6
75	2250	1355	1000	S6
100	3000	1807	1330	S6 + S6
125	3750	2259	1656	S4 + Rack
150	4500	2711	1987	S4 + Rack
200	5000	3597	2650	S4 + Rack
250	-	4518	3312	S4 + Rack
300	-	5000	3974	S4 + Rack

110 VOLT				
CELL MODEL	1 HOUR	2 HOUR	3 HOUR	CUBICLE
15	990	596	440	S6
30	1980	1193	875	S5 + S5
45	2970	1789	1315	S6 + S6
60	3960	2385	1750	S6 + S6
75	4950	2982	2190	S6 + S6
100	6600	3976	2930	S4 + Rack
125	8250	4946	3630	S4 + Rack
150	9900	5935	4363	S4 + Rack
200	11000	7913	5830	S4 + Rack
250	-	9892	7260	S4 + Rack
300	-	11000	8726	S4 + Rack

## Sealed Lead Acid Batteries

Valve regulated gas recombination lead acid batteries comply with BS 6290 Part 4 with a design life of 10 years @ 20°C.

24 VOLT				
CELL MODEL	1 HOUR	2 HOUR	3 HOUR	CUBICLE
24	312	189	137	S4
38	495	288	218	S4
48	626	379	275	S4
65	847	513	372	S4
78	1016	615	447	S4
100	1440	888	636	S4
160	2300	1420	1017	S4
200	2400	1775	1272	S4/1
320	–	2400	2035	S4
480	–	–	2400	S5

50 VOLT				
CELL MODEL	1 HOUR	2 HOUR	3 HOUR	CUBICLE
24	626	379	274	S4
38	990	600	435	S4
48	1251	758	548	S4
65	1694	1026	745	S4
78	2033	1232	895	S4
100	2880	1776	1272	S4/1
160	4608	2842	2035	S4/1
200	5000	3552	2544	S5/2
320	–	5000	4070	S6/2
480	–	–	5000	2S5/2

110 VOLT				
CELL MODEL	1 HOUR	2 HOUR	3 HOUR	CUBICLE
24	1320	806	595	S4
38	2099	1276	942	S4
48	2652	1612	1190	S4/1
65	3591	2183	1611	S4/1
78	4309	2620	1933	S5/2
100	6480	3888	2808	S5/2
160	10368	6221	4493	S6/2
200	11000	7776	5616	2S5/2
320	–	11000	8986	2S6
480	–	–	11000	3S6

# Battery Systems Wattage Ratings

## Nickel Cadmium (NC)

Nickel cadmium alkaline batteries, designed to EN 60623 (IEC 623), are of rugged perforated pocket plate construction designed for a 20 year life.

24 VOLT				
CELL MODEL	1 HOUR	2 HOUR	3 HOUR	CUBICLE
9	116	80	63	S4
14	181	125	97	S4
22	286	197	153	S4
31	401	276	216	S4
39	504	348	271	S4
47	607	420	326	S4
55	710	492	384	S4
70	943	631	490	S4
90	1214	811	629	S4
110	1483	991	768	S4
130	1754	1171	907	S5/1
165	2225	1488	1152	S5/1
185	2400	1668	1294	S5/1
215	–	1937	1502	S5/1
240	–	2162	1678	S5/1
285	–	2400	1992	S5/1
310	–	–	2165	S5/1
335	–	–	2340	S5/1
370	–	–	2400	S6/1

50 VOLT				
CELL MODEL	1 HOUR	2 HOUR	3 HOUR	CUBICLE
9	243	168	131	S4
14	378	261	203	S4
22	595	410	319	S4
31	835	575	450	S4
39	1050	725	565	S5/1
47	1265	875	680	S5/1
55	1480	1025	800	S5/1
70	1965	1315	1020	S5/1
90	2530	1690	1310	S5/1
110	3090	2065	1600	S5/1
130	3655	2440	1890	S6/1
165	4635	3100	2400	S6/1
185	5000	3475	2695	S6/1
215	–	4035	3130	S6/1
240	–	4505	3495	S6/1
285	–	5000	4150	2 x S5/1
310	–	–	4510	2 x S5/1
335	–	–	4875	2 x S5/1
370	–	–	5000	2 x S6/1

110 VOLT				
CELL MODEL	1 HOUR	2 HOUR	3 HOUR	CUBICLE
9	534	369	287	S6
14	831	573	447	S6
22	1309	901	702	S6
31	1837	1265	990	S6
39	2310	1595	1243	S6/1
47	2783	1925	1496	S6/1
55	3256	2255	1760	S6/1
70	4323	2893	2244	2 x S6/1
90	5566	3718	2882	2 x S6/1
110	6798	4543	3520	2 x S6/1
130	8041	5368	4158	2 x S6/1
165	10197	6820	5280	2 x S6/1
185	11000	7645	5929	2 x S6/1
215	–	8877	6886	2 x S6/1
240	–	9911	7689	2 x S6/1
285	–	1100	9130	3 x S6/1
310	–	–	9922	3 x S6/1
335	–	–	10725	3 x S6/1
370	–	–	11000	4 x S6/1

# Sub-circuit Monitoring

## Maintained Battery System

It is a requirement of an emergency lighting scheme that the emergency lighting is present in a total mains failure or a local lighting circuit failure. If a maintained central battery system is used the emergency lighting will be on all the time, whatever the status of the mains both generally or locally, which means no local sub-circuit monitoring is required. However, when non-maintained emergency lighting is required, it is possible to use a maintained central battery system and hold off relays to achieve local lighting circuit failure monitoring.

The local sub-circuit energises the relays and when the mains is healthy the output from the central battery system is prevented from powering the emergency lighting. When the local sub-circuit fails the relay becomes de-energised and allows the output from the central battery system to power the emergency lights. In this situation the load will be supplied AC via a transformer built into the system, so the battery is not discharged. This has the advantage that when there is a total mains failure the battery will be in a fully charged condition.

Maintained Central Battery System

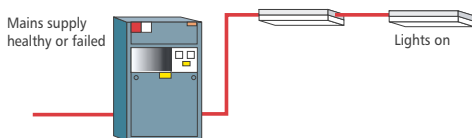

Maintained Central Battery System using hold-off relays to provide Non-maintained Lighting

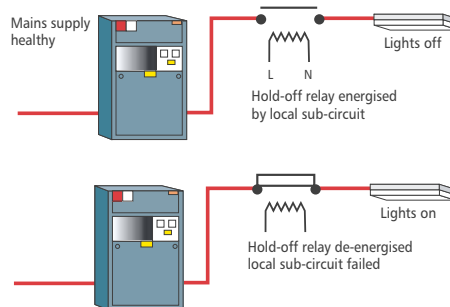

## Non-maintained Battery System

A non-maintained battery system output will only be connected to the emergency lighting if the mains supply fails. Therefore, if a local lighting circuit fails, the area covered by this circuit will be in total darkness. To prevent this from occurring, sub-circuit relays should connect to each local lighting circuit and the normally open contacts of these relays are wired in series and connected into a link in the central system's control circuitry. When all the local circuits are healthy the relay contacts are all closed, so the circuit is complete and the changeover contactor in the central battery system is open, hence preventing the battery from being connected to the load.

If one lighting circuit fails, its monitoring relay de-energises and the contacts open and the control circuitry becomes open circuit. This results in the changeover contactor in the central system closing and connecting the battery onto the emergency lighting. This then results in the battery being discharged. Bardic can supply these sub-circuit relays mounted into an enclosure. Please consult our technical sales office for further details.

Non-maintained Central Battery System

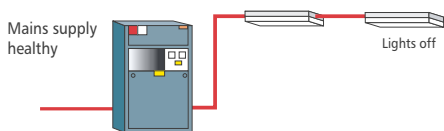

Non-maintained Central Battery System with sub-circuit monitoring

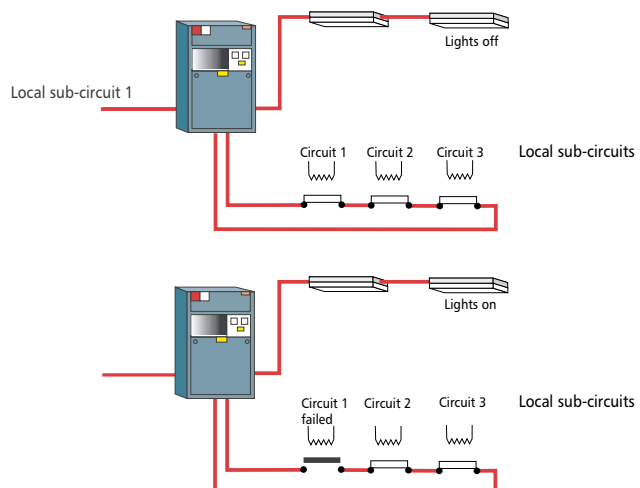

# Central Battery Systems

## Advantages / Disadvantages



### Advantages / disadvantages

The testing of a central battery system is much easier than with a self-contained system because it can be done from one central point.

Systems are usually located in areas where only authorised personnel are allowed to enter, e.g. plant room, substation, switch room.

The slave fittings can be housed in a hotter environment than self-contained fittings because the battery can be housed in a cooler area.

The battery in a central battery system can have a design life of up to 25 years. In self-contained units the batteries must be changed every 4 years, which is a time consuming and disruptive process.

When Central Battery Systems Batteries are required to be changed it is much easier and quicker.

Much higher lighting levels can be achieved using central battery systems.

# Switch Tripping Systems Features and Technical

A flexible and comprehensive range of integrated charger and battery systems for use with all types of rechargeable standby power batteries. Bardic's Switch Tripping Systems have been specifically designed to provide a cost effective and secure DC power supply in a broad range of applications. The range is designed with versatility as a key priority ensuring that every system installed offers the performance to meet the application requirements. Indeed, Bardic's Switch Tripping Systems incorporate technology of proven performance and reliability, already tested in such disparate applications as offshore oil platforms and petrochemical sites, and in a diversity of climatic conditions. However diverse the application there is a Bardic Switch Tripping System which, with the many functions and flexible options, represents the ideal solution. Typical system applications installed around the world include switch tripping, engine starting, continuous DC loads and telecommunications support.

## Features

- Low cost
- Comprehensive monitoring
- Wide range
- Flexible options
- Proven performance and reliability

## Technical

Systems can be engineered to accurately maintain the state of charge of the battery whilst providing the load supply, be that intermittent, continuous, or mixed.

On floating systems for intermediate loads – i.e. switch tripping, closing and engine starting, the battery supplies the load and its capacity is maintained by the charger. On floating systems for continuous loads – i.e. telecommunications, telemetry and process control, the charger must be rated to supply simultaneously both the maximum continuous load and the recharge requirements of the battery. Thus the load is supplied by the charger and the battery maintains continuity to the load on failure of the normal supply.

Bardic Switch Tripping Systems are suitable for use with all types of rechargeable battery, including both vented and sealed recombination electrolyte types. In addition to maintaining battery charge and operating load, Bardic Switch Tripping Systems provide comprehensive condition control, monitoring, protection and alarm functions, creating the complete operation and security system. Input, output, float, boost and charge voltages are monitored and controlled with local LED indicators and remote alarm functions providing warnings, and security features preventing unauthorised operation of the system.

To meet the specific requirements of individual applications, various options can be added to the charger. These include:

- Autoboot
- CCITT output smoothing
- Double pole output distribution fuses or circuit breakers
- Earth fault monitor
- Battery fuses
- Battery over-discharge protection
- Auxiliary relays
- Supply fail alarm
- Battery shelf tiering
- Vermin proofing
- Charger only

Systems may be rack or cubicle mounted as preferred, and wall mounted cubicles are available for smaller units. The compact wall mounted cubicles available are suited for low voltage systems, particularly those with sealed batteries.

Type S2 will accommodate sealed cell lead acid and vented cell lead acid and nickel cadmium batteries. The cubicle can accommodate 3A chargers at 24, 30 or 50V and 7.5A chargers at 24 or 30V.

Type S7 is a low cost unit for small 24 and 30V battery systems with 3A or 7.5A chargers.

Three floor-standing cubicles are available – Types S4, 5 and 6. Between them they accommodate the full range of Switch Tripping Systems. For higher capacity systems additional matching battery cubicles may be added.

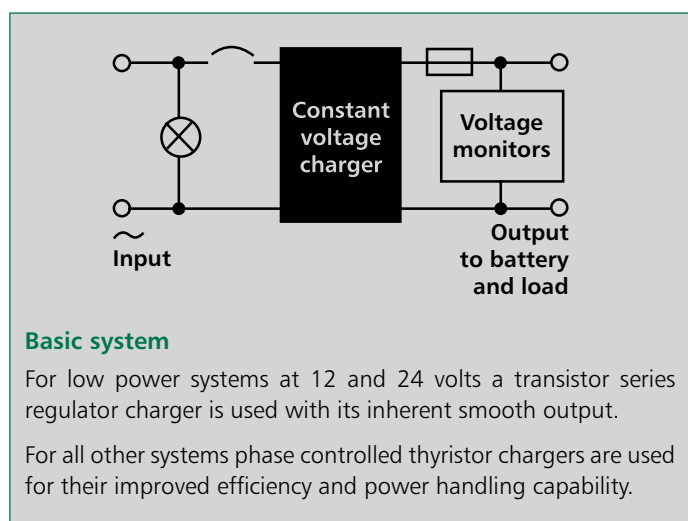

# Charger Specifications

## Thyristor charger

A constant voltage charger with current limit.

RATINGS (OTHER RATINGS AVAILABLE ON REQUEST)					
AC input	220-240V +/-10% Single Phase 47-63Hz				
	24V	30V	50V	110V	240V
Charger output	7.5A 15A 25A	7.5A 15A 3A	7.5A 15A 25A 3A	7.5A 15A 25A	3A 6A 10A 15A

NOMINAL VOLTAGE AND NUMBER OF CELLS		
CHARGER VOLTAGE	NOMINAL NUMBER OF CELLS	
	LEAD ACID	NICKEL CADMIUM
24	10-13	18-21
30	13-22	21-36
50	22-26	36-42
110	50-57	84-92
240	105-125	157-200

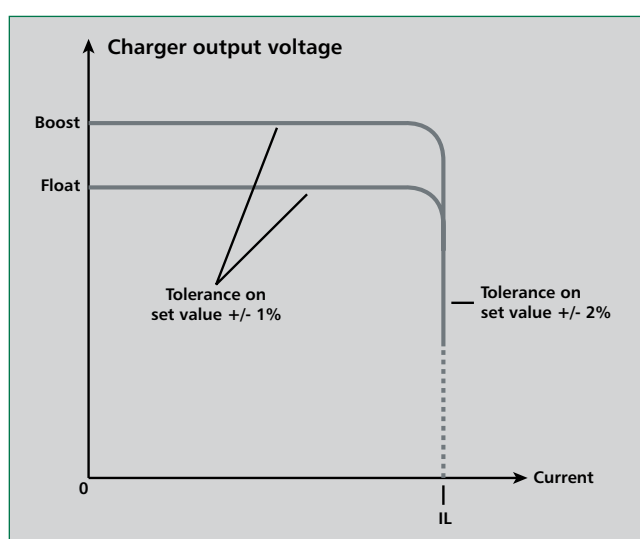

THYRISTOR CHARGERS CHARACTERISTICS	
DC output	Switchable to "float" or "boost" voltage setting as characteristic 1 of DIN 41773
Output stability	+/- 1% of "float" voltage under variation of (i) 0-100% load current and (ii) +/- 10% AC supply voltage and (iii) +/- 5% of nominal AC supply frequency (50 or 60Hz)
Voltage adjustment	Separate adjustment of "float" and "boost" voltage over ranges shown in table below
Output ripple voltage	<1% rms with battery connected (battery capacity less than 6 x charger current rating)
Ripple current	AC ripple current less than 2% of charger nominal DC current rating
Current limit performance	+/- 2% of nominal setting over the voltage range 2.0 to 2.4 volts per cell (Lead Acid) or 1.2 to 1.45 volts per cell (Nickel Cadmium Alkaline)
Current limit adjustment	To cover 25-105% of rated charger output
Ambient temperature	Nominal rating at 25°C derated up to 55°C. Operating range -10°C to +55°C

VOLTAGE ADJUSTMENT RANGE		
CHARGER MODE	VOLTS PER CELLS	
	LEAD ACID	NICKEL CADMIUM
Float	2.15-2.40	1.38-1.55
Boost	2.40-2.70	1.55-1.70
Boost setting must be 5% higher than float setting. Voltages given are applicable with any numbers of the cells shown above		

# Charger Specifications

## Transistor charger

A constant voltage charger with current limit and fold back short circuit protection.

RATINGS	
AC input	220-240V +/-10% Single Phase 47-63Hz
Charger output	3A at 12V, 24V or 30V
DC output	Switchable to 'float' or 'boost' voltage settings

NOMINAL VOLTAGE AND NUMBER OF CELLS		
CHARGER VOLTAGE	NOMINAL NUMBER OF CELLS	
	LEAD ACID	NICKEL CADMIUM
12	5-7	9-11
24	10-13	18-21
30	13-16	21-25

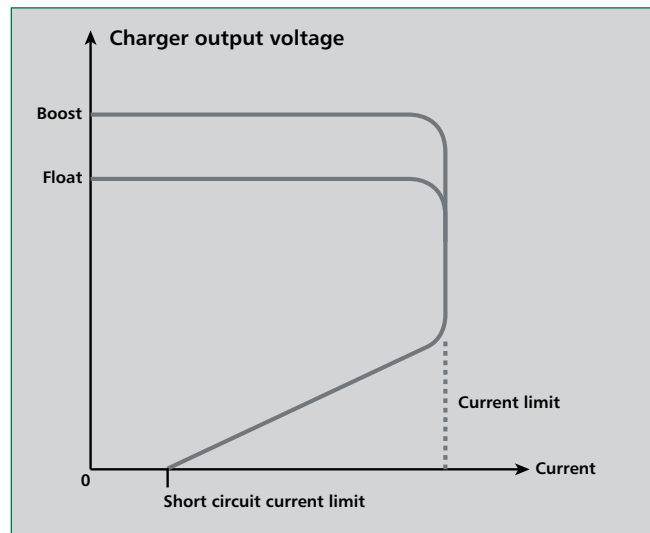

CONTROL AND MONITORING – ALL CHARGERS	
<b>CONTROLS</b>	
AC input switch	Single pole MCB with padlocking facility
Float / boost	Tamper resistant key switch Key retained in "boost" (Boost not required for sealed lead acid systems)
<b>LED INDICATION OF</b>	
Red	Supply on
Green	Float charge
Amber	Boost charge
Amber	Charge fail
Amber	Low voltage
Amber	High voltage
And optional additional Amber indication of up to five items including:	Earth fault Supply fail
<b>ALARMS</b>	
A single volt free changeover contact is provided to give a remote summary alarm indication of:	Low voltage High voltage Charge fail
And optionally up to five items including:	Earth fault Supply fail
Contact rating	3A @ 240V AC or 24V DC, 0.4A @ 240V DC Individual remote indication may be provided by adding the optional slave relays as required
<b>METERING</b>	
DIN 72 metres with 90° scale	Battery voltage Charger output current
Option	One additional similar meter

# Cubicle Specifications

CUBICLE SPECIFICATIONS	
Construction	Folded sheet steel construction generally 1.6mm thick mild steel
Access to charger	Via a screw fixed removable cover
Access to battery	Wall mounted cubicles – via screw fixed removable covers Floor standing cubicles – via hinged lockable doors fitted with two carriage locks Two keys are supplied The S4 and S5 cubicles have one door and S6 cubicles have two doors On larger systems, using two or more cubicles, the top compartment may be used for accommodating cells Access to these is via screw fixed covers
Access to distribution and battery fuses / circuit breakers	Wall mounted cubicles – via screw retained panels Floor standing cubicles – via panels retained by quick release clips
Cable entry	S2 wall mounted cubicles – via undrilled bottom gland plate in charger mounting plate S7 wall mounted cubicles – via two 20mm conduit entries in right hand side panel Floor standing cubicles – via undrilled full width gland plate at top of cubicle
Natural ventilation	Wall mounted cubicles – via louvres in base and back or sides Floor standing cubicles – battery compartment via louvres in back panel Floor standing cubicles – charger compartment via top and louvres in back panel
Finish	Acid and alkaline attack resistant acrylic textured semi-gloss stove enamel to BS 381C shade 631 light grey

DIMENSIONS (MM)			
WALL MOUNTED	S2	S7	
Height	610	570	
Width	750	510	
Depth	400	370	
Fixing centres	300 x 670	100 x 470	
Fixings	4 holes 12mm dia	4 holes 12mm dia	
FLOOR STANDING	S4	S5	S6
Height	1330	1730	1730
Width	750	750	1050
Depth	560	560	560

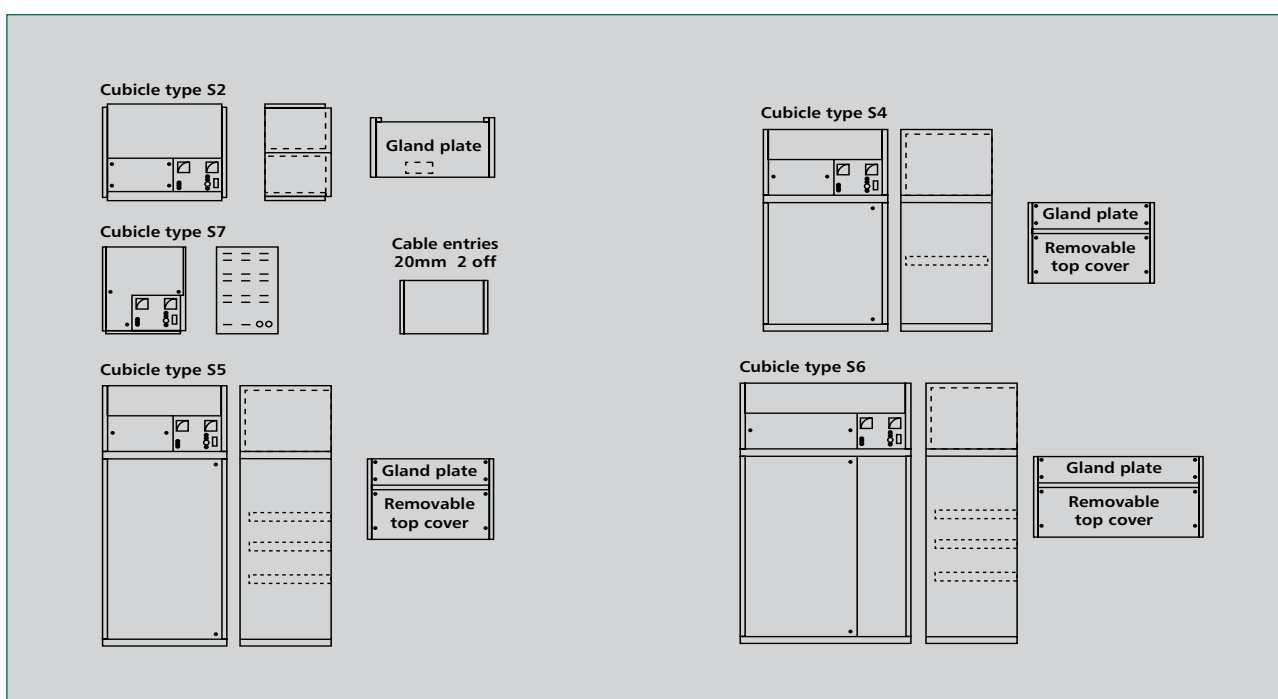

# Switch Tripping Systems Options

OPTION	CODE	DESCRIPTION
Auto boost	A	This facility automatically selects a timed boost charge following discharge of the battery Not suitable for sealed lead acid batteries
CCITT smoothing	C	For communications applications, additional filtering components can be added to the charger output to limit the output voltage ripple (with the battery disconnected) to within CITT limits
Distributions	D	Output distribution double pole circuit breakers or fuses can be added to all switch tripping systems The number is limited only by the space available
		<b>Wall mounted cubicles</b> S2 3DP ways, MCBs to 40A max, fuses to 63A max S7 1DP way, fused to 32A max
		<b>Floor standing cubicles S4/5</b> MCBs 5DP ways up to 40A @ 50V DC max 4DP ways up to 100A @ 110V DC max Fuses 4DP ways up to 63A 3DP ways up to 100A
		<b>Floor standing cubicles S6</b> MCBs 10 ways up to 40A @ 50V DC 8 ways up to 100A @ 110V DC Fuses 8 ways up to 63A 6 ways up to 100A
Earth fault alarm	E	This detects excessive earth leakage current on either pole of the DC output Local indication is provided by an LED, remote indication is provided by the summary alarm contact Fault polarity indication can be given by fitting two modules
Battery fuses	F	Battery fuses can be provided, rated up to 100A for wall mounted systems and 400A for floor standing systems
Battery over-discharge protection	L	To prevent over-discharge of the battery, a latched contactor disconnects the battery when the low volt alarm operates The battery is automatically reconnected when the AC supply is restored This contactor must be rated to suit the maximum load current and is available in four ratings – 12, 25, 45 and 100A
Charger only	H	No batteries supplied with system
Special paint finish	P	Where necessary the cubicles can be finished in a customer's preferred colour or finish
Individual alarm relays	R	A common voltage free contact is always supplied as standard, which will operate if any alarm occurs Individual alarm relays can be fitted to allow remote indication of a particular alarm state Each has a single pole changeover contact rated at 3A @ 240V AC or 24V DC, 0.4A @ 240V DC
AC supply fail alarm	S	AC supply failure will normally be signalled by loss of the supply present indication and by the charge fail alarm The supply fail alarm module provides specific LED indication of supply failure
Basic systems	T	Where simplicity is required, and operational requirements allow, all alarms and the output ammeter may be omitted
Non standard	X	The flexibility of the Bardic switch tripping systems allows specially engineered systems with non standard options to be produced quickly and at low cost
		<b>Tiered battery shelves</b> Where required, these can be added to raise the back rows of cells for improved access and to enable all cell electrolyte levels to be seen clearly
		<b>Vermin proofing</b> Where vermin are likely to prove a problem, 3.5mm maximum aperture mesh can be fitted over all ventilation louvres

# Switch Tripping Systems Range

The model number of each Bardic switch tripping system is coded to enable you to identify the charger rating, the battery type and capacity, the cubicle size and which optional extras have been fitted. Thus a new system may be specified or an existing system identified by the model number. precise details such as the number and rating of distribution ways, the duration of the timed auto boost etc., are specified separately, e.g. TP2/24/3/AE/S4/L65 is a 24V 3A system with auto boost and an earth fault monitor in floor standing S4 cubicle with a nickel cadmium L type 65Ah capacity battery.

MODEL RANGE	SWITCH TRIPPING SELF CONTAINED SYSTEM		
Charger V	Nominal voltage		
Output A	Maximum current		
Options	A	Auto boost	
	C	CCITT smoothing	
	D	Distribution fuses	
	E	Earth fault monitor	
	F	Battery fuses	
	H	Charger only	
	L	Battery over-discharge protection	
	P	Special paint finish	
	R	Auxiliary alarm relays	
	S	Supply fail alarm	
	T	Tripping unit – no alarms or ammeter	
X	Non-standard option		
	Note: If no options required use O in option box		
Cubicles	S2	Wall mounted to 50V	
	S4	Floor standing	
	S5	Floor standing	
	S6	Floor standing	
	S7	Wall mounted to 30V	
BATTERY TYPE AND CAPACITY (AH)	NICKEL CADMIUM		LEAD ACID (VENTED)
	L	LCE Range	P Planté
	M	MC Range	
	H	HC Range	
			LEAD ACID (SEALED)
			S SLA

**BARDIC**

by Honeywell

---

Waterside Road Hamilton Industrial Park Leicester LE5 1TN United Kingdom

**Tel** +44 (0)116 246 2212

**Website** [www.bardic.co.uk](http://www.bardic.co.uk)

**Fax** +44 (0)116 246 2210